

CT BOLTING SERIES

Hydraulic Torque Wrench



CanTorque Inc.
www.cantorque.com



CT Series

Hydraulic Torque Wrench



Specifications

| | |
|--------------|--|
| Calibration | Individually calibrated & certified |
| Couplers | Non-drip quick connect couplers with 4:1 safety ratio |
| Design | Extremely simple and efficient |
| Drive | Fixed square drive-maximum strength Optional Allen Hex Drives, Direct Drive Sockets and Custom Drives available upon request |
| Housing | CNC machined from aircraft grade aluminum |
| Piston | Numerically machined on 11 axis lathe-from billet to finished product in 1 setup |
| Ratchet | Multi tooth engagement distributes load over greater area |
| Reaction arm | First in class magnetic reaction arm assembly using patented On/Off magnet technology. Simplifies attachment and removal of reaction arm and accessories. |
| Swivel | Dual 360° swivel |

Specifications may change without notice.

Technical

| Model No. | Imperial Square Driver Size | Torque Lbf/ft | | Metric Torque NM | |
|-----------|--------------------------------|---------------|-------|---------------------|-------|
| | | Min | Max | Min | Max |
| CT-2 | 3/4" | 127 | 1270 | 170 | 1720 |
| CT-3 | 1" | 330 | 3330 | 447 | 4470 |
| CT-7 | 1 1/2" | 740 | 7400 | 1000 | 10000 |
| CT-11 | 1 1/2" | 1100 | 11010 | 1490 | 14900 |
| CT-20 | 2 1/2" | 2220 | 22200 | 3000 | 30000 |
| CT-27 | 2 1/2" | 2720 | 27200 | 3685 | 36850 |
| CT-60 | 2 1/2" | 5800 | 58000 | 7860 | 78600 |



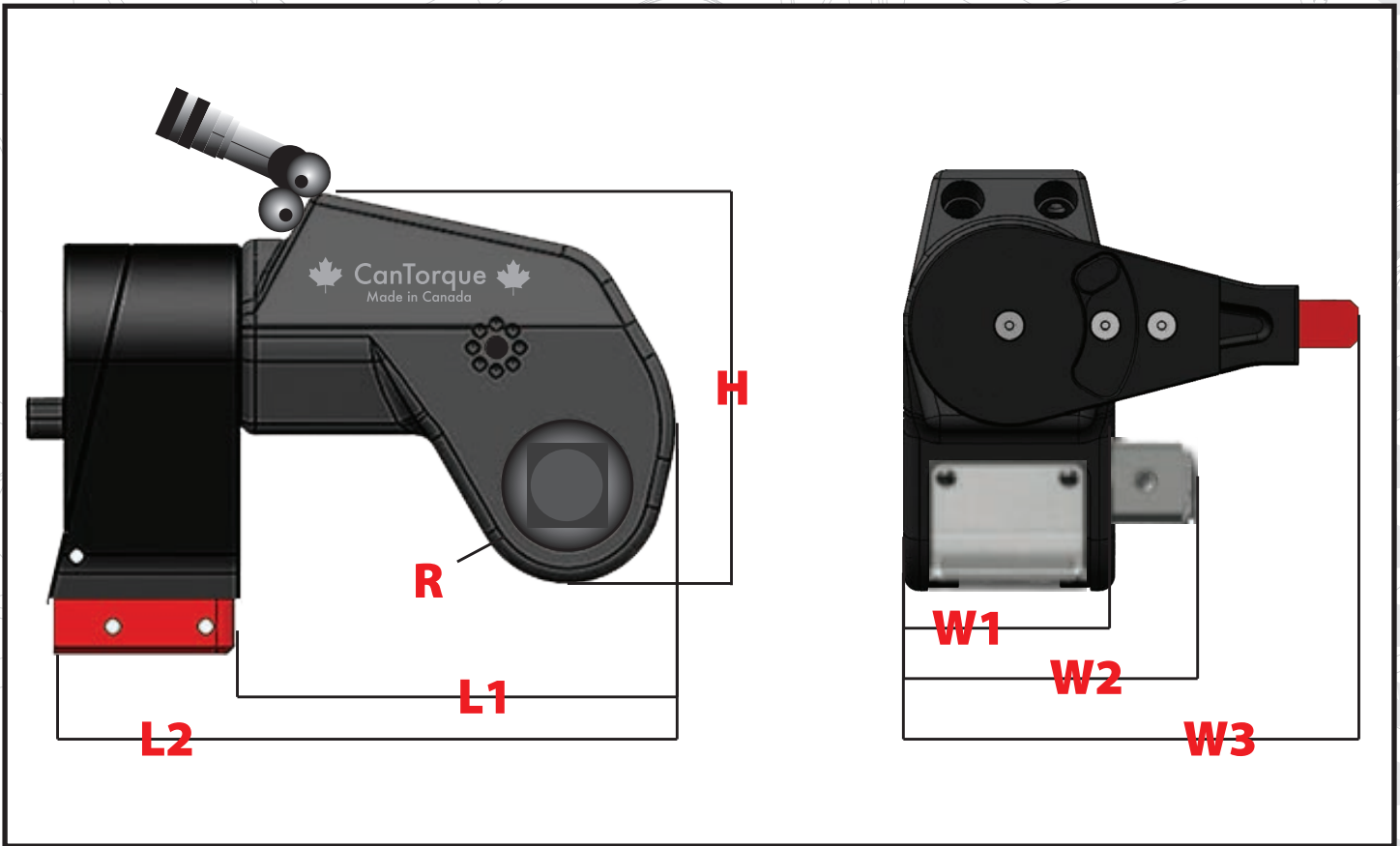

Dimensions

Imperial

| Model No. | Weight lbs | Height inch | L1 inch | L2 inch | Radius inch | W1 inch | W2 inch | W3 inch |
|-----------|---------------|----------------|------------|------------|----------------|------------|------------|------------|
| CT-2 | 4.00 | 4.13 | 4.76 | 6.29 | 0.98 | 2.01 | 2.81 | 4.25 |
| CT-3 | 9.30 | 5.15 | 6.18 | 8.17 | 1.30 | 2.70 | 3.72 | 5.85 |
| CT-7 | 19.60 | 6.92 | 8.07 | 10.86 | 1.70 | 3.68 | 5.13 | 7.95 |
| CT-11 | 30.00 | 7.80 | 9.44 | 12.33 | 1.95 | 3.93 | 5.47 | 8.75 |
| CT-20 | 62.70 | 9.27 | 9.45 | 16.14 | 2.33 | 4.88 | 7.16 | 11.00 |
| CT-27 | 72.20 | 10.22 | 12.53 | 16.36 | 2.43 | 5.26 | 7.79 | 11.70 |
| CT-60 | 134.00 | 11.61 | 15.48 | 20.51 | 2.90 | 6.60 | 8.93 | 14.56 |

Metric

| Model No. | Weight kg | Height mm | L1 mm | L2 mm | Radius mm | W1 mm | W2 mm | W3 mm |
|-----------|--------------|--------------|----------|----------|--------------|----------|----------|----------|
| CT-2 | 1.85 | 105.00 | 121.00 | 160.00 | 25.00 | 51.20 | 71.60 | 108.00 |
| CT-3 | 4.20 | 131.00 | 157.00 | 207.70 | 33.00 | 68.50 | 94.70 | 148.70 |
| CT-7 | 8.90 | 175.90 | 205.00 | 276.00 | 43.25 | 93.50 | 130.40 | 202.00 |
| CT-11 | 13.60 | 198.20 | 240.00 | 313.33 | 49.70 | 99.90 | 139.00 | 222.50 |
| CT-20 | 28.50 | 235.50 | 240.20 | 410.10 | 59.20 | 124.20 | 182.10 | 279.00 |
| CT-27 | 32.75 | 259.70 | 318.30 | 415.70 | 61.90 | 133.80 | 198.00 | 297.00 |
| CT-60 | 60.80 | 295.00 | 393.30 | 521.00 | 73.80 | 167.50 | 227.00 | 370.00 |

Note: All tool weights include Couplers, Swivels, Reaction Arm and Internal Oil.



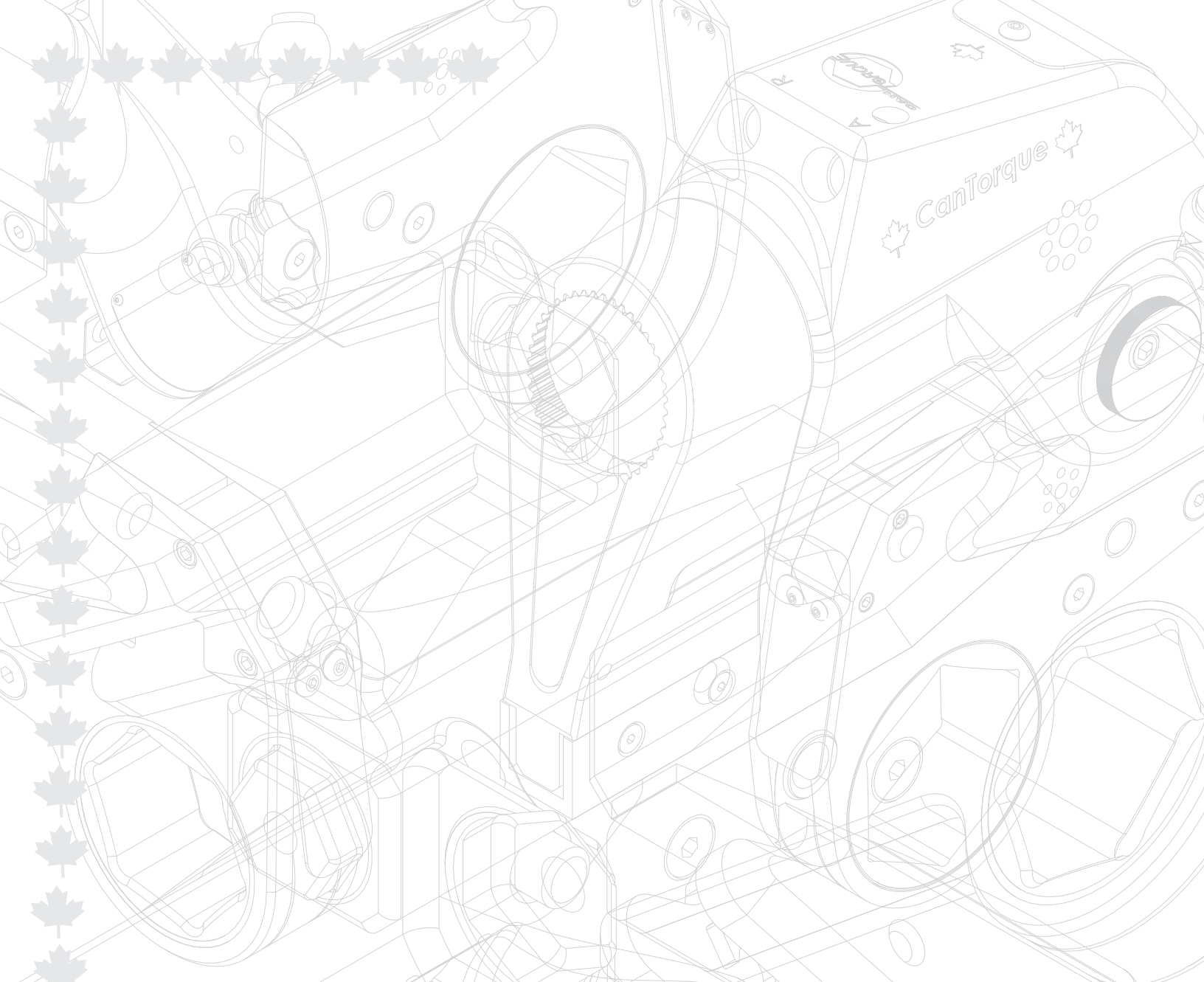

Authorized Distributor

CanTorque Inc. products are warranted free of defects in material and workmanship for a period of one (1) year from date of shipment. This warranty does not include failures due to application of torque to transducers or loaders beyond the stated capacity, operating system with a damaged transducer cord, nor any other misuse, abuse, or tampering. When used with impact type wrenches, the warranty is limited to the electronic digital display units only. This warranty does not cover calibrations. All freight charges are the responsibility of the company or individual returning the item(s) for repair. Freight collect shipments will not be accepted. Any modification to any of this equipment, without the express written approval of CanTorque Inc. will void this warranty. CanTorque Inc. disclaims any and all liability, obligation or responsibility for the modified product; and any claims, demands or causes of action for damage or for personal injuries resulting from the modification and/or use of such a modified CanTorque Inc. product.



info@cantorque.com

14635 119 Avenue
Edmonton, AB T5L 2N9
Twitter: [@cantorque](https://twitter.com/cantorque)
www.cantorque.com

Main: +1 780 436 2000
Fax: +1 780 732 0905
Toll Free: +1 877 436 4364